

TECHNICAL CHARACTERISTICS

ANCHOR SYSTEM

AGL

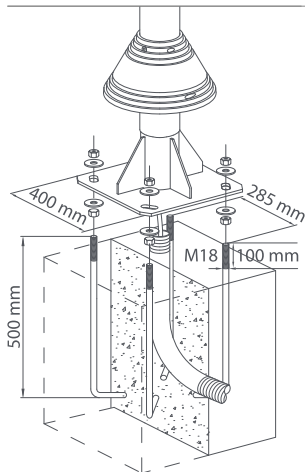

SECTIONS

SINERGY TUBE Ø 75

Interior
Tube Ø 70 x 4
Galvanized Steel

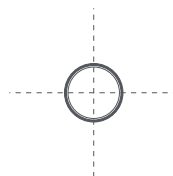

Exterior
Tube Ø 75 x 2,5
Engineered Technical
Polymers

SINERGY TUBE Ø 205

Interior
Tube Ø 200 x 4
Galvanized Steel

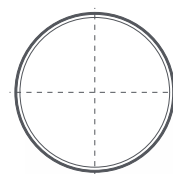

Exterior
Tube Ø 205 x 2,5
Engineered Technical
Polymers

SPECIFICATIONS

INSULATION LEVEL

CLASS II (UNE EN 60598)

AENOR CERTIFICATE

Nº 019/000131

CE CERTIFICATE OF CONFORMITY

0099/CDP/A55/A0099

AGM

