

Alameda S

ATP lighting
10 YEAR WARRANTY
IMMUNE TO CORROSION
STREET LIGHTING

 **Standard colours**
Other colours available on demand.



N Black



GC Light grey



GO Dark grey



V Green

Technical specifications

Coupling

Ø 60 mm.

Adaptor

Ø 50 mm.

LED voltage

220-240 V 50-60 Hz

Electronic discharge voltage

208-277 V 50-60 Hz

Electromagnetic discharge voltage

230 V 50 Hz / 220 V, 240 V 60 Hz

Recommended maximum height

12 m.

Weight without gear

6,9 kg.

Photocell

On request.

Protection grades



Exclusive technology



Electrical class



Warranty



Dimensions

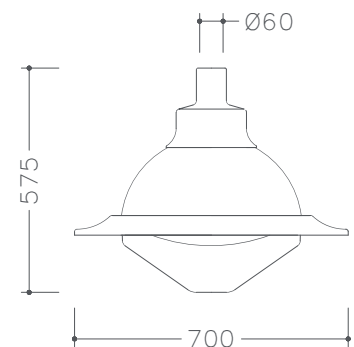

Certificates



NOM



CE



UKCA



ENEC



ISSOP



Certificado CB

Available optics



100W Max.



100W Max.



100W Max.



100W Max.



100W Max.



100W Máx.

Colour temperatures



PC AMBER



1800 K



2200 K



2700 K



3000 K



4000 K

 Designed and manufactured integrally by ATP in Europe

ATP LIGHTING INTERNATIONAL, S.A.
Chlupfgasse 2 · 8303 Bassersdorf · Switzerland
info@atplighting.com · www.atplighting.com